

LIFTKET

WORKS SINCE 1948

INDUSTRY



CUSTOM



STAGE



LIFTKET - HISTORY WITH A FUTURE

Much has changed since the company was founded in 1948. One thing, however, has always remained the same: The quality of LIFTKET products - Made in Wurzen, Germany.

Over three generations, the company's ingenious founder Dietrich Hoffmann has set the standard for electric-chain hoists used worldwide today. The horizontal arrangement of engine and gearbox as well as the patented safety-brake coupling system are just two stellar examples.

The spirit of innovation, adherence to only the highest standards and attention to detail have been the hallmarks of Wurzener Lifting Equipment for more than 70 years. In keeping with this philosophy, the needs of both our customers and partners are at the core of our endeavors. This spirit is influential in shaping and designing LIFTKET products, making them the best on the market. Hundreds of thousands electric chain hoists in action across the globe bear an impressive testimony of faith in our products.

As one of the world's oldest and largest manufacturers of electric-chain hoists LIFTKET will respond to an increasing demand by optimizing and expanding its own production capacities.

We are shaping the future as we speak, so that we will continue to be your number-one choice tomorrow.

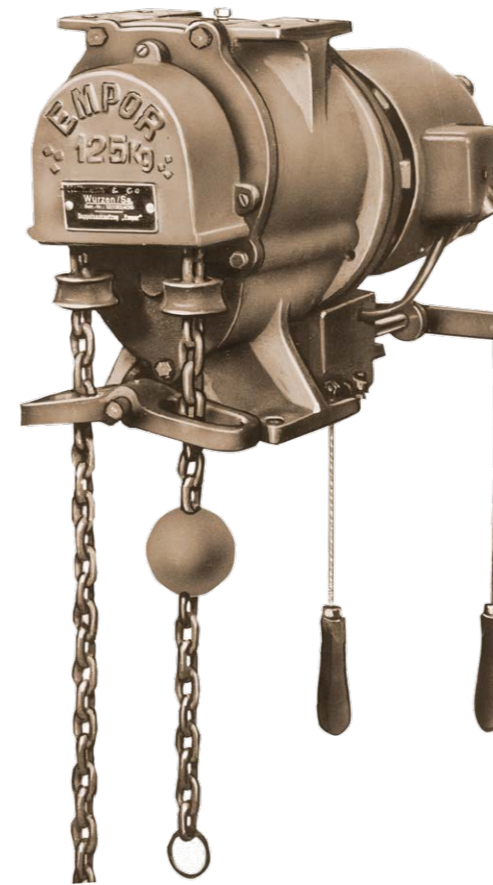

LIFTKET – FOCUS ON QUALITY

LIFTKET moves - safely and everywhere, and any load of up to 25,000 kg and 200 meters.

Around 250 employees in the heart of Germany ensure that thousands of LIFETEKS leave our plant every month. Every single electric-chain hoist was designed, developed, produced and tested here with sufficient load bearing capacity. A unique ID makes it possible to trace exactly when a particular electric-chain hoist was built – and who built it with which materials - even after 10 years.

Numerous customers and OEM partners in over 65 countries rely on LIFTKET quality products. Safety, durability, ease of maintenance, service and a fair price/performance ratio are particularly valued.

A worldwide network of service and sales partners also guarantees short distances and fast availability of spare and wear parts. As early as 1953, we already focused exclusively on the production of electric-chain hoists - for any conceivable application. A high vertical range of manufacture and almost limitless customization capabilities ensure that you can work just the way you want, be it with LIFTKET branding or OEM products, standardized series or individual solutions.



LIFTKET

INDUSTRY

LIFTKET electric-chain hoists are used in almost every sector of industry. Whether it's for a stonemason or the food industry, shipyards or power stations – we lift and move weights in a safe, precise and reliable way.

The LIFTKET product portfolio offers you standardized hoists that can be adjusted to your requirements in a modular way, as well as highly specialized solutions. Larger lifting and operating heights are just as viable as deviating voltages and special solutions of any kind.

You tell us what you want to move – and we will develop and supply the perfect solution.

FEATURES

From 80 kg to 25,000 kg we lift everything that moves you • FEM ratings from Fem 1Bm to 4m (ISO M3 to M7) • Protection class IP55, insulation class F • Galvanised load chain to DIN 818-7 quality class DAT • A wide range of options can be selected as standard • Optional one or two lifting speeds from 2 to 32 m/min • With heavy-duty end position switch-off as standard (at 24VAC)

STATIONARY VERSION

- Stationary version with hook or eye
- Eye (connection between crane and trolley) compatible with all commercially available trolleys and suspensions

STAR VFD

- Load-dependent, infinitely variable control from 2 to 36 m/min
- Up to 200 % faster without load
- Easy-to-read display with operating hours, remaining service life according to FEM
- Brake cycles and starts

TROLLEYS // BOGIES

- Manual or electric trolleys in various designs for each steel section girder
- Short suspension and precise horizontally suspended hoist due to two-bolt suspension
- High-quality, galvanized impellers and fall protections

LIFTKET

CUSTOM

You need it extra-short? Extra-high? Extra-long? Extra-fast? Extra-customized? Are you looking for single pieces in serial production? Batch size one? Then you've come to the right place at LIFTKET!

Decades of experience, professional ability and our willingness to master any challenge brings our tailor-made applications to life – even when produced in series. You benefit from the best quality and innovative technology. And our own developments and production from a single source render your custom products real.

Your individuality is our reality. Just watch your dreams come to life!



APPLICATIONS FOR INDIVIDUAL SOLUTIONS

Any application deviating from the standard, e.g. foundry • Power stations • Food industry • Modernisation and conversion of old industrial plants • Pharmaceutical industry • Water treatment

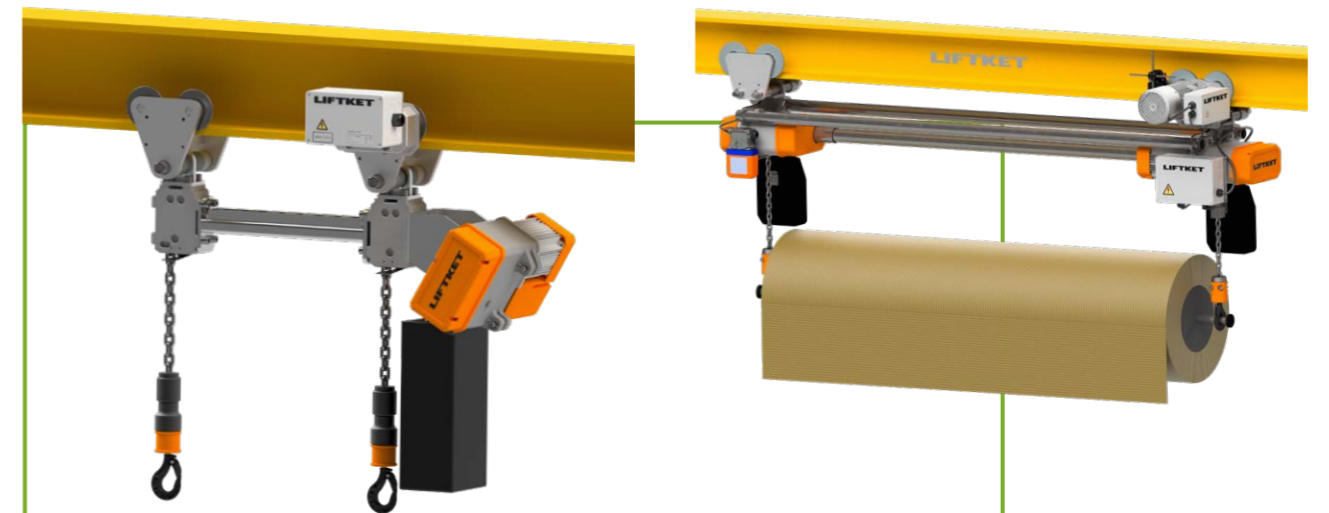

SPECIAL SOLUTIONS

Selection of flexibly configurable features:

- Lifting height and lifting speeds
- Space heaters
- Special corrosion protection up to C5 in any colour
- All control and operating voltages
- Versions for foundries
- Second hoist brake
- Load measuring equipment
- Extra short chassis
- Trolleys for curved tracks
- Gear-type limit switch with several switching points
- Encoder for positioning and automatic mode

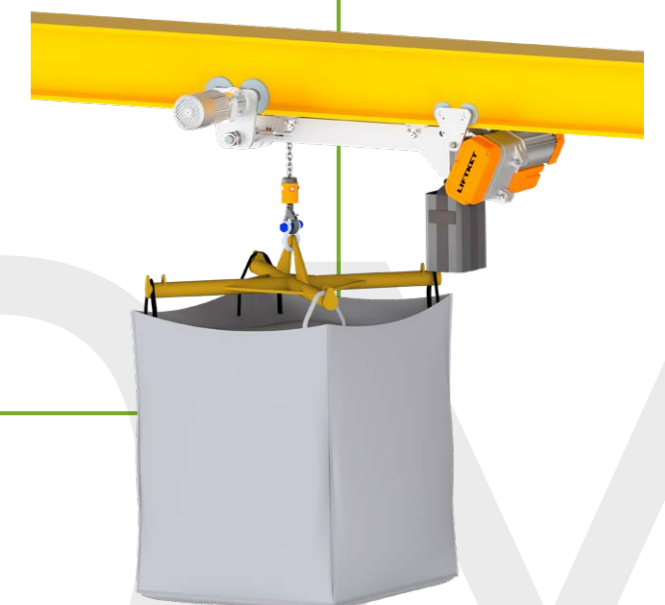
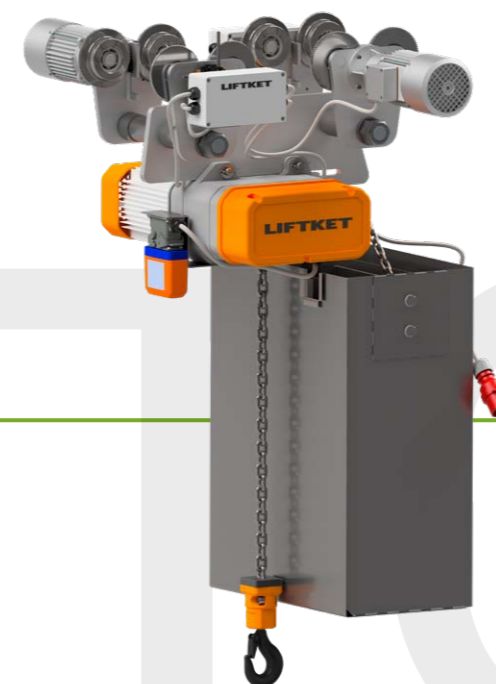

LIFTKET

STAGE

Specially developed for applications in the field of lighting, stage and event technology, the STAGEKET electric chain hoists are capable of lifting loads from 125 kg to 6,300 kg. Safely, quietly, and - if desired - customized to your individual needs.

Our customers and visitors alike appreciate the compact design, easy handling and proven LIFTKET quality on site around the world.

We move with high-tech and at high-speed when engaged at mobile events or at fixed installations, thereby making moments move.

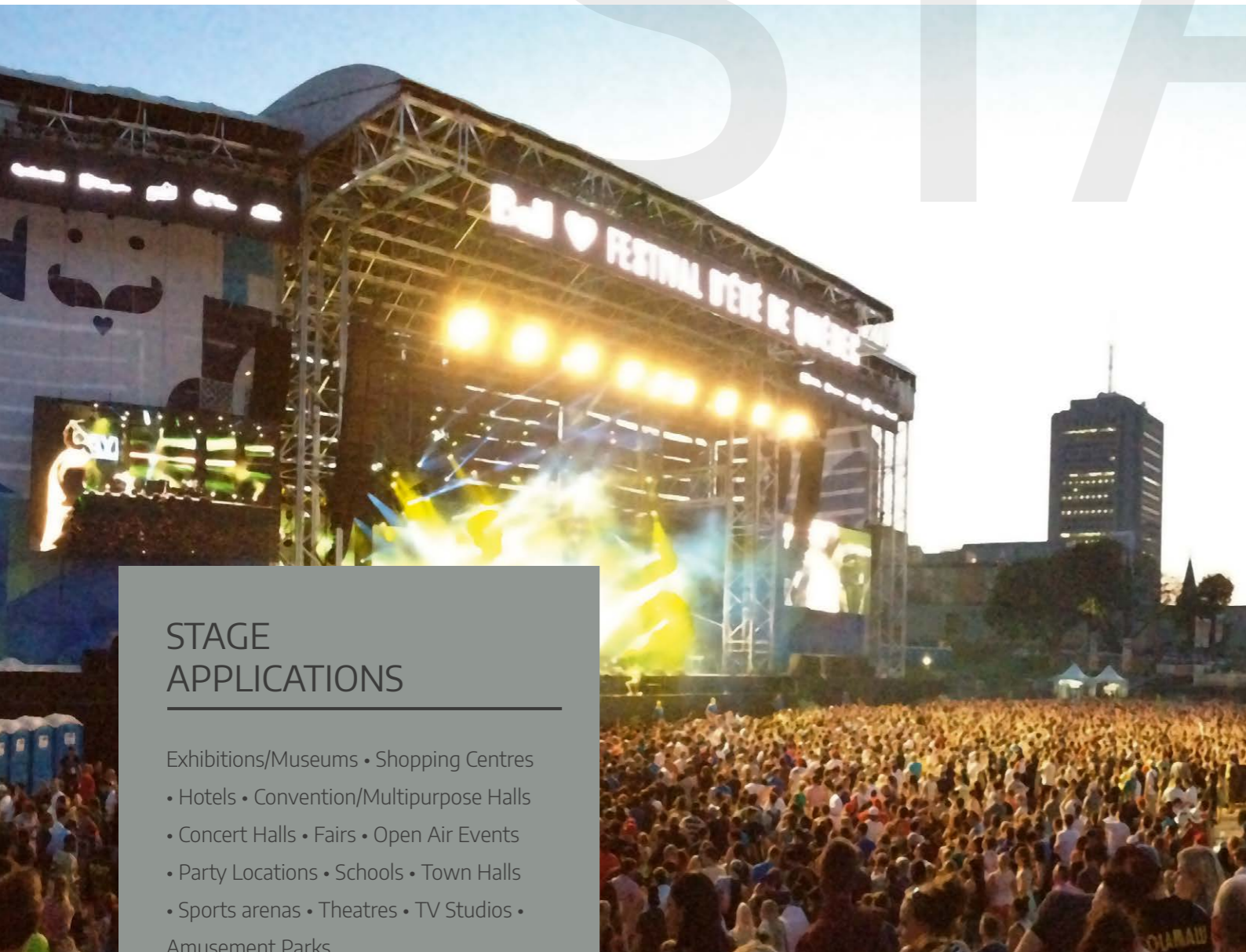

STAGE APPLICATIONS

Exhibitions/Museums • Shopping Centres
• Hotels • Convention/Multipurpose Halls
• Concert Halls • Fairs • Open Air Events
• Party Locations • Schools • Town Halls
• Sports arenas • Theatres • TV Studios •
Amusement Parks

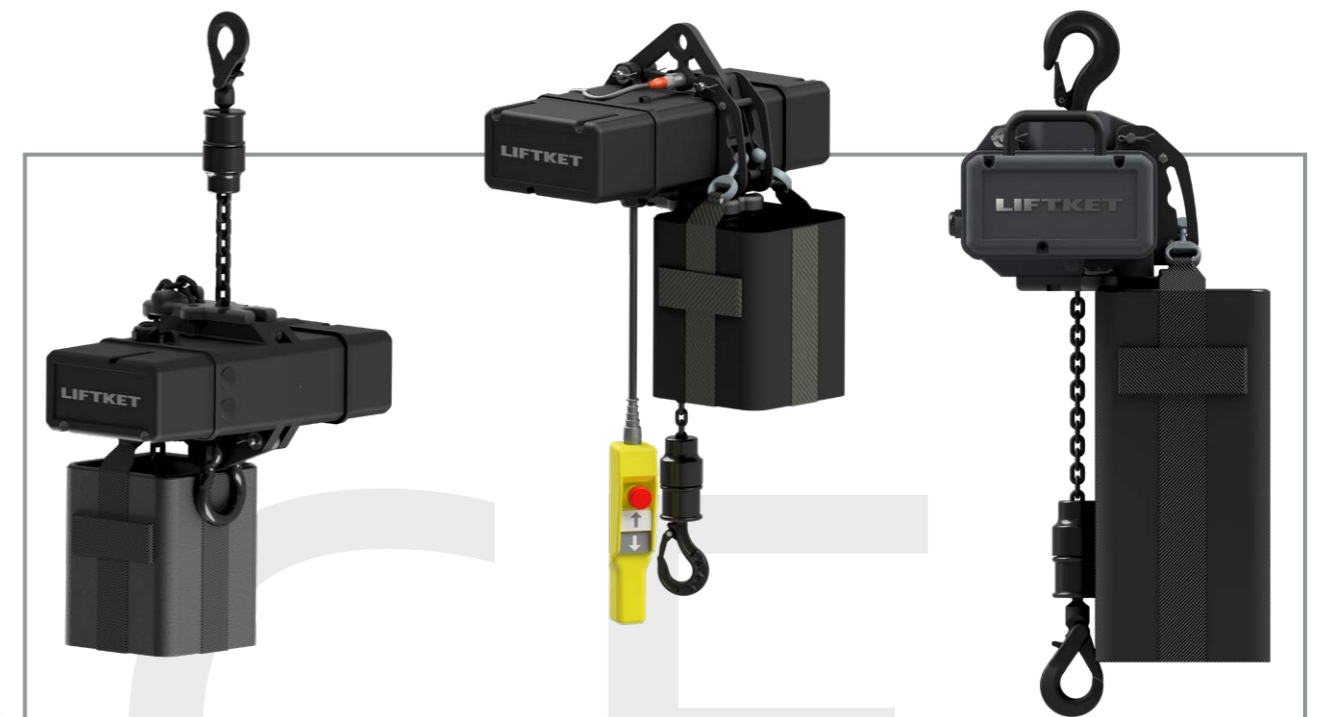

FEATURES

- Use in normal or climbing position
- Simple assembly and disassembly
- Electromagnetic brake, optionally with additional safety brake
- Flip bag chain box that adapts itself to the installation position
- Galvanized or black phosphate load chain DAT according to DIN EN 818-7
- Direct or contactor control
- Low noise emission
- Optionally with gear limit switch and incremental encoder as well as sturdy and ergonomic handles made of aluminium
- Electronic load recording according to DGUV V17 standard (ehm. BGV C1)





QUALITY SINCE 1948 – MADE IN GERMANY

In Wurzen near Leipzig, electric chain hoists have been developed and produced for more than 70 years, sustainably defining the technology and safety standard for the entire industry.
LIFTKET – our quality is your strength.



LIFTKET

WORKS SINCE 1948

LIFTKET Hoffmann GmbH

Dresdener Straße 64-68

D-04808 Wurzen · Germany

Phone: +49 3425 8924-0

Fax: +49 3425 8924-99

E-Mail: sales@liftket.de

Internet: www.liftket.de